

PROJECT:

QUANTITY:

ITEM: NO:

Cafeteria

PORTABLE SNEEZEGUARD – PSG 19

MODELS: PSG1936, PSG 1938, PSG 1948, PSG 1960, PSG 1972, PSG 1976, PSG 1996

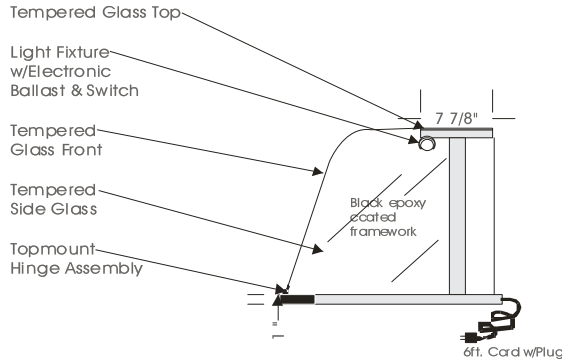

SIDE ELEVATION

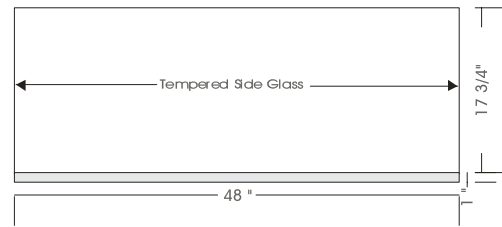

FRONT ELEVATION



SPECIFICATIONS

MODEL	DIMENSIONS	ELECTRICAL	SHIPPING WT.
PSG 1936	36"L.X20½"D.X19"H.	115V/1/60HZ/0.50 AMP	100 lb.
PSG 1938	38"L.X20½"D.X19"H.	115V/1/60HZ/0.50 AMP	100 lb.
PSG 1948	48"L.X20½"D.X19"H.	115V/1/60HZ/0.60 AMP	110 lb.
PSG 1960	60"L.X20½"D.X19"H.	115V/1/60HZ/0.75 AMP	130 lb.
PSG 1972	72"L.X20½"D.X19"H.	115V/1/60HZ/1.00 AMP	160 lb.
PSG 1976	76"L.X20½"D.X19"H.	115V/1/60HZ/1.00 AMP	170 lb.
PSG 1996	96"L.X20½"D.X19"H.	115V/1/60HZ/1.25 AMP	200 lb.

STANDARD FEATURES

1. Top light.
2. Tempered curved front glass tilt forward.
3. Clear satin anodized aluminum hinge and framework.
4. Stainless steel framework.
5. Tempered top side glass removable.

OPTIONS

1. Powder coated hinge and framework.
2. Additional shelf light.
3. Additional epoxy coated wire shelf.

*Due to constant improvements, specifications are subject to change without notice.



Canadian Display Systems Inc.

177 Westcreek Drive, Woodbridge, Ontario L4L 9N6
 Ph: 905-265-7888, 1-800-895-5862 Fax: 905-265-7692
 email cds1@on.cibn.com
www.canadiandisplayssystem.com